

Country Oaks Office Park

**Eight Office Buildings
3,500 s.f. each**

**7165 Getwell Road
Southaven, Mississippi**

For More Information:

**Chuck Roberts
Chuck Roberts Commercial Real Estate
662.349.7775 or 662.404.1111**



w w w . c h u c k r o b e r t s . c o m

Country Oaks Office Park

Southaven, Mississippi

Property Facts:

- Approximately 3.2 acres located along the west side of Getwell Road just north of Goodman Road in Southaven, Mississippi.
- Part of the Country Oaks Development
- Located in a professional office area featuring a number of professionals and corporations such as BancorpSouth.

Subdivision Facts:

- The property has been divided into 8 lots as approved by the City of Southaven.
- Buildings sizes are 3,500 s.f. with approximately 2,400 s.f. on the ground floor and an additional 1,100 s.f. located on the second floor.
- The office park features an internal network of sidewalks for protected pedestrian access, screened dumpster locations for easy access by tenants and building owners, a small lake along Getwell, integrated landscaping and irrigation and a coordinated, custom building design.
- Two entrances off of Getwell serve as the subdivision's primary points of ingress/egress.

Development Facts:

- At completion, the subdivision will contain a total of 8 buildings featuring approximately 28,000 s.f. of total professional office space.
- Country Oaks is being developed as a professional office campus with common maintenance of all grounds in order to maintain the highest level of professional standard at all times throughout the park.
- The buildings are uniquely designed to meet the needs of the business owner looking for building ownership or the investor looking for a long-term successful investment.

Country Oaks Office Park

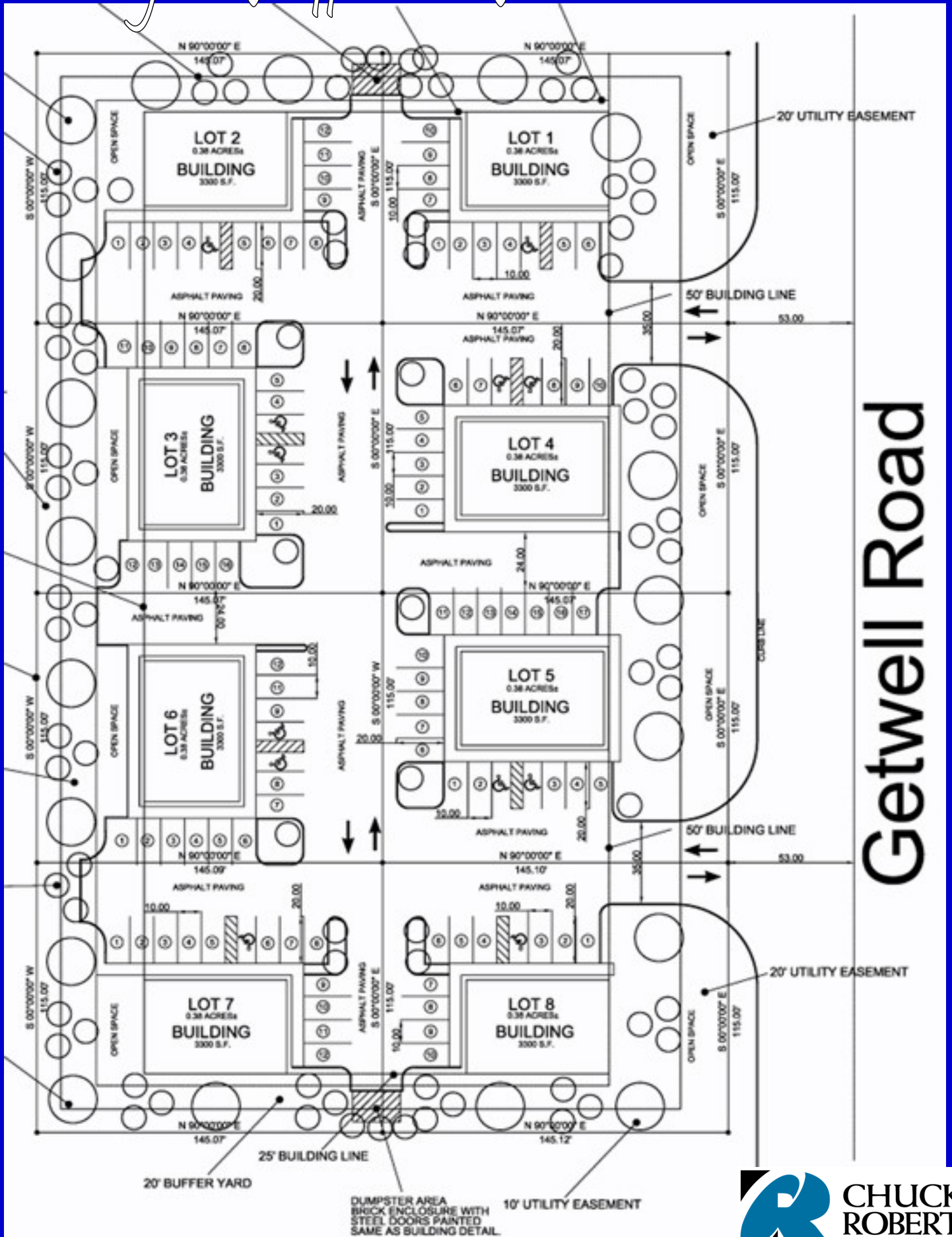

Getwell Road

*Country Oaks Office Park
Southaven, MS*

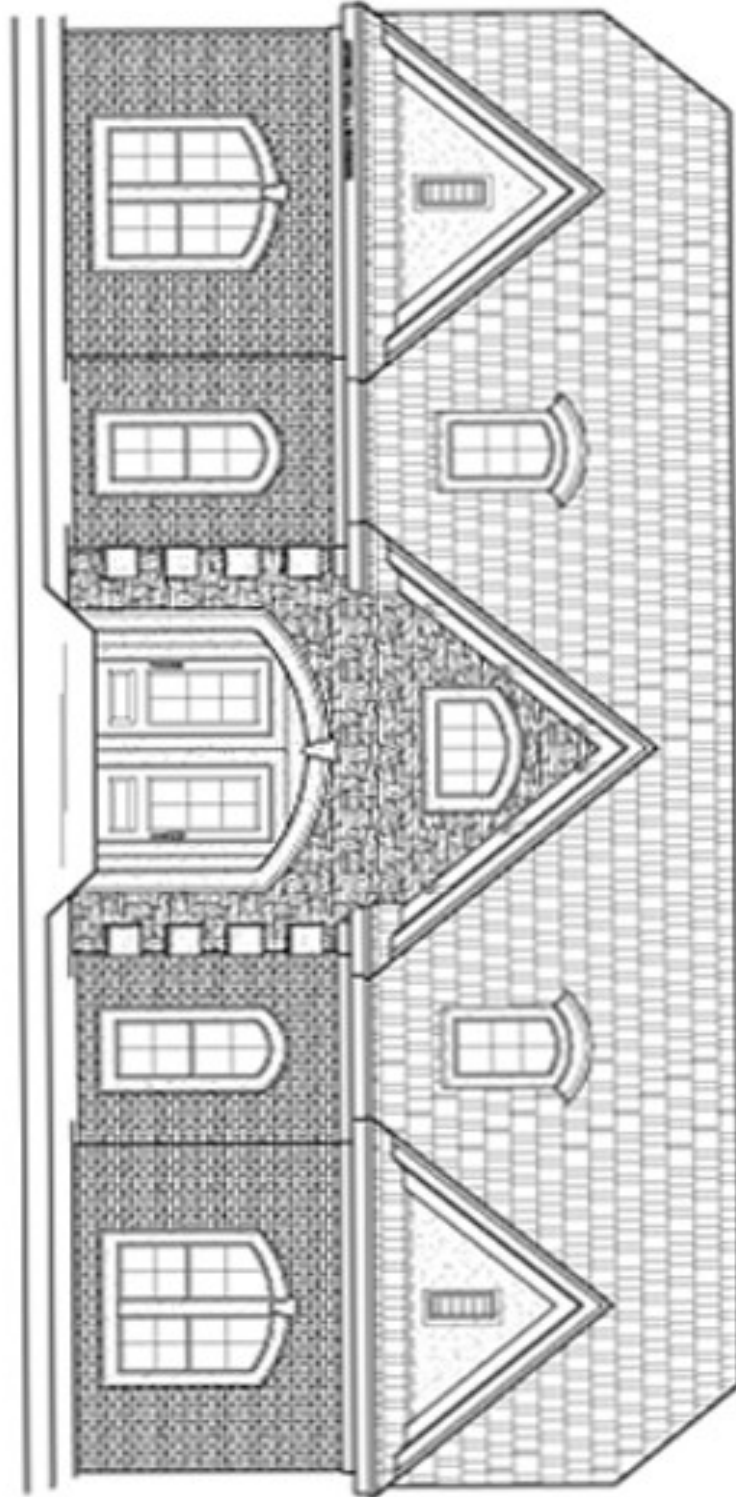

Country Oaks Office Park Southaven, MS



Country Oaks Office Park

Southaven, MS

Building Information

Building Number	Square Feet	Asking Price
A	3,500SF	Contract Pending
B	3,500SF	\$425,000
C	3,500SF	\$425,000
D	3,500SF	Contract Pending
E	3,500SF	\$375,000
F	3,500SF	\$375,000
G	3,500SF	\$375,000
H	3,500SF	\$375,000

